

TPS7B770x-Q1 Single- and Dual-Channel Antenna LDO With Current Sense

1 Features

- Qualified for Automotive Applications
- AEC-Q100 Qualified With the Following Results:
 - Device Temperature Grade 1: -40°C to 125°C Ambient Operating Temperature Range
 - Device HBM ESD Classification 2
 - Device CDM ESD Classification C4B
- Single and Dual-Channel LDO With Current Sense and Adjustable Current-Limit
- 4.5- to 40-V Wide Input Voltage Range, 45-V Load Dump
- Power Switch Mode When Tying FB to GND
- 1.5- to 20-V Adjustable Output Voltage
- Up to 300-mA Output Current per Channel
- Adjustable Current-Limit With External Resistor
- High Accuracy Current-Sense to Detect Antenna Open Condition at Low Current Without Further Calibration
- High Power-Supply Rejection Ratio: Typical 73 dB at 100 Hz
- Integrated Reverse-Polarity Protection, Down to -40 V and No Need for External Diode
- 500-mV maximum Dropout Voltage at 100-mA Load
- Stable With Output Capacitor in 2.2 to 100- μF Range (ESR 1 m Ω to 5 Ω)
- Integrated Protection and Diagnostics
 - Thermal Shutdown
 - Undervoltage Lock Out
 - Short Circuit Protection
 - Reverse Battery Polarity Protection
 - Reverse Current Protection
 - Output Short-to-Battery Protection
 - Output Inductive Load Clamp
 - Multiplexing Current Sense Between Channels and Devices
 - Ability to Distinguish all Faults With Current Sense
- 16-Pin HTSSOP PowerPad™ Package

2 Applications

- Infotainment Active-Antenna Power Supply
- Surround-View Camera Power Supply
- High-Side Power Switch For Small Current Applications

3 Description

The TPS7B770x-Q1 family of devices is a single and dual high-voltage LDO with current sensing designed to operate with a wide input-voltage range from 4.5 to 40 V (45-V load dump protection). The device provides power to the low-noise amplifiers of the active antenna through a coax cable with 300 mA per channel current. Each channel also provides an adjustable output voltage from 1.5 to 20 V.

The device provides diagnostics through the current sense and error pins. To monitor the load current, a high-side current-sense circuitry provides a proportional analog output to the sensed load current. The accurate current sense allows detection of open, normal, and short-circuit conditions without the need for further calibration. Current sense can be multiplexed between channels and devices to save ADC resources. Each channel also implements adjustable current limit with an external resistor.

The integrated reverse polarity diode eliminates the need for an external diode. The device features standard thermal shutdown, short-to-battery protection on the output, and reverse current protection.

Each channel has internal inductive clamp protection on the output during inductive switch off. The device operates during -40°C to 125°C ambient temperature range.

Device Information⁽¹⁾

PART NUMBER	PACKAGE	CHANNEL
TPS7B7701-Q1	HTSSOP (16)	Single
TPS7B7702-Q1		Dual

(1) For all available packages, see the orderable addendum at the end of the data sheet.

Application Diagram

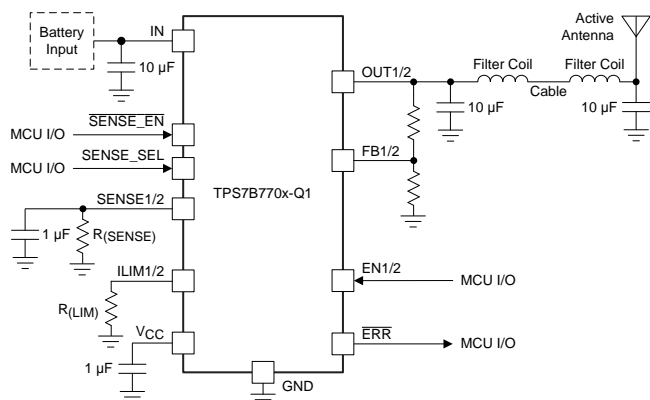

Table of Contents

1 Features 1 2 Applications 1 3 Description 1 4 Revision History 2 5 Pin Configuration and Functions 3 6 Specifications 5 6.1 Absolute Maximum Ratings 5 6.2 ESD Ratings 5 6.3 Recommended Operating Conditions 5 6.4 Thermal Information 6 6.5 Electrical Characteristics 6 6.6 Switching Characteristics 7 6.7 Typical Characteristics 8 7 Detailed Description 11 7.1 Overview 11 7.2 Functional Block Diagram 11 7.3 Feature Description 11	7.4 Device Functional Modes 15 8 Application and Implementation 16 8.1 Application Information 16 8.2 Typical Application 16 9 Power Supply Recommendations 19 10 Layout 19 10.1 Layout Guidelines 19 10.2 Layout Example 20 11 Device and Documentation Support 20 11.1 Documentation Support 20 11.2 Related Links 20 11.3 Community Resource 21 11.4 Trademarks 21 11.5 Electrostatic Discharge Caution 21 11.6 Glossary 21 12 Mechanical, Packaging, and Orderable Information 21
--	---

4 Revision History

NOTE: Page numbers for previous revisions may differ from page numbers in the current version.

Changes from Revision A (May 2015) to Revision B	Page
• Deleted the min and max limits of –4% and 4% from the current-limit threshold voltage parameter in the <i>Electrical Characteristics</i> table	7
• Added to the current-limit accuracy table note for the programmable current-limit accuracy parameter in the <i>Electrical Characteristics</i> table	7
• Added graphs for the TPS7B7701-Q1 device in the <i>Typical Characteristics</i> section	8
• Deleted the channel 2 PSRR graph in the <i>Typical Characteristics</i> section	8
• Added additional test conditions for the 9- to 16-V <i>Line Transient</i> and <i>Power Up</i> graphs in the <i>Typical Characteristics</i> section	10
• Added additional test conditions of the <i>Power Up</i> graphs in the <i>Application Curves</i> section	19

Changes from Original (January 2015) to Revision A	Page
• Released the full version of the data sheet	1

5 Pin Configuration and Functions

Single-Channel TPS7B7701QPWPRQ1
PWP Package, 16-Pin HTSSOP With PowerPAD
Top View

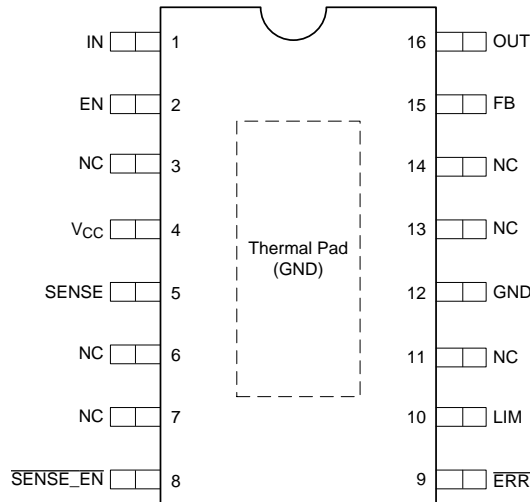

NC — no internal connection

Dual-Channel TPS7B7702-Q1QPWPRQ1
PWP Package, 16-Pin HTSSOP With PowerPAD
Top View

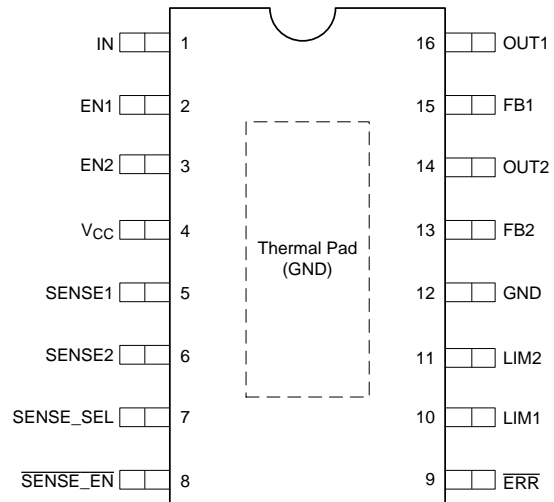

Pin Functions

NAME	PIN		TYPE ⁽¹⁾	DESCRIPTION
	SINGLE-CHANNEL	DUAL-CHANNEL		
EN	2	—	I	Active-high enable input for the OUT pin with internal pull down
EN1	—	2	I	Active-high enable input for the OUT1 pin with internal pulldown
EN2	—	3	I	Active-high enable input for the OUT2 pin with internal pulldown
ERR	9	9	O	This pin is an open-drain fault indicator for general faults
FB	15	—	I	Feedback input for setting the OUT voltage. Connect FB to GND to select current-limited switch operation
FB1	—	15	I	Feedback input for setting the OUT1 voltage. Connect FB1 to GND to select current-limited switch operation
FB2	—	13	I	Feedback input for setting the OUT2 voltage. Connect FB2 to GND to select current-limited switch operation
GND	12	12	G	Ground reference
IN	1	1	P	Input power-supply voltage
LIM	10	—	O	Programmable current-limit pin. Connect a resistor to GND to set the current limitation level. This pin does not need an external capacitor. To set to internal current limit, short this pin to GND.
LIM1	—	10	O	Programmable current-limit pin for channel 1. Connect a resistor to GND to set the current limitation level for channel 1. This pin does not need an external capacitor. To set to internal current limit, short this pin to GND.
LIM2	—	11	O	Programmable current-limit pin for channel 2. Connect a resistor to GND to set the current limitation level for channel 2. This pin does not need an external capacitor. To set to internal current limit, short this pin to GND.
NC	3	—	—	Connect the NC pins to ground or leave floating.
	6			
	7			
	11			
	13			
OUT	16	—	P	Output voltage
OUT1	—	16	P	Output voltage 1
OUT2	—	14	P	Output voltage 2

(1) I = input, O = output, P = power, G = ground

Pin Functions (continued)

NAME	PIN		TYPE ⁽¹⁾	DESCRIPTION
	SINGLE-CHANNEL	DUAL-CHANNEL		
SENSE	5	—	O	Output of current sense for sensing. To set the SENSE output voltage level, connect a resistor between this pin and GND. In addition, connect a 1- μ F capacitor from this pin to GND for frequency compensation of the current-sense loop. Short this pin to GND if not used.
SENSE1	—	5	O	Output of current sense for sensing. SENSE1 current is proportional to the current flow through OUT1 and SENSE 2 current is proportional to OUT2 current when SENSE_SEL and $\overline{\text{SENSE_EN}}$ are low. To set the SENSEx output voltage level, connect a resistor between this pin and GND. In addition, connect a 1- μ F capacitor from the SENSEx pin to GND for frequency compensation of the current-sense loop. Short the SENSEx pin to GND if not used.
SENSE2	—	6	O	
$\overline{\text{SENSE_EN}}$	8	8	I	This pin is the enable and disable of the current-sense pin for multiplexing, active-low enable.
SENSE_SEL	—	7	I	This pin selects the current sense between channel 1 and channel 2. See Table 2 for more information
V _{CC}	4	4	O	Internal 4.5-V regulator. Connect a 1- μ F ceramic capacitor between V _{CC} and GND for frequency compensation

6 Specifications

6.1 Absolute Maximum Ratings

over operating free-air temperature range (unless otherwise noted) ⁽¹⁾

		MIN	MAX	UNIT
Input voltage	Unregulated input, IN	-40	45	V
	EN, EN1, and EN2	-0.3	45	V
Regulated output ⁽²⁾	V _{CC} ⁽³⁾⁽⁴⁾	-0.3	6	V
	OUT1 and OUT2	-0.3	45	V
Low-voltage pins	SENSE, SENSE1, and SENSE2 ⁽³⁾⁽⁴⁾	-0.3	V _{CC} + 0.3	V
	LIM, LIM1, LIM2, $\overline{\text{SENSE_EN}}$, SENSE_SEL, $\overline{\text{ERR}}$, FB, FB1, and FB2 ⁽³⁾⁽⁴⁾	-0.3	7	V
Operating junction temperature, T _J		-40	150	°C
Operating ambient temperature, T _A		-40	125	°C
Storage Temperature, T _{stg}		-65	150	°C

- (1) Stresses beyond those listed under *Absolute Maximum Ratings* may cause permanent damage to the device. These are stress ratings only, which do not imply functional operation of the device at these or any other conditions beyond those indicated under *Recommended Operating Conditions*. Exposure to absolute-maximum-rated conditions for extended periods may affect device reliability.
- (2) There is an internal diode connects between the OUT and GND pins with 300-mA DC current capability for inductive clamp protection.
- (3) All voltage values are with respect to GND.
- (4) Absolute maximum voltage.

6.2 ESD Ratings

		VALUE	UNIT	
V _(ESD) Electrostatic discharge	Human body model (HBM), per AEC Q100-002 ⁽¹⁾	±2000	V	
	Charged device model (CDM), per AEC Q100-011	Corner pins (1, 8, 9, and 16)		±750
		Other pins		±500

- (1) AEC Q100-002 indicates HBM stressing is done in accordance with the ANSI/ESDA/JEDEC JS-001 specification.

6.3 Recommended Operating Conditions

over operating free-air temperature range (unless otherwise noted)

		MIN	MAX	UNIT
V _I	Unregulated input	4.5	40	V
	EN, EN1, and EN2	0	40	V
Low-voltage pins	SENSE, SENSE1, SENSE2, $\overline{\text{SENSE_EN}}$, SEN_SEL, $\overline{\text{ERR}}$, FB, FB1, FB2, LIM, LIM1, LIM2, and V _{CC}	0	5.3	V
	OUT1, OUT2, and OUT	1.5	20	V
C _O	Output capacitor stability range	2.2	100	μF
C _{O(ESR)}	Output capacitor ESR stability range	0.001	5	Ω
T _J	Junction temperature	-40	150	°C

6.4 Thermal Information

THERMAL METRIC ⁽¹⁾		TPS7B7701-Q1	TPS7B7702-Q1	UNIT
		PWP (HTSSOP)	PWP (HTSSOP)	
		16 PINS	16 PINS	
R _{θJA}	Junction-to-ambient thermal resistance ⁽²⁾	45.9	40.3	°C/W
R _{θJC(top)}	Junction-to-case (top) thermal resistance	29.2	27.7	°C/W
R _{θJB}	Junction-to-board thermal resistance	24.7	22.3	°C/W
ψ _{JT}	Junction-to-top characterization parameter	1.3	0.8	°C/W
ψ _{JB}	Junction-to-board characterization parameter	24.5	22	°C/W
R _{θJC(bot)}	Junction-to-case (bottom) thermal resistance	3.7	2.7	°C/W

- (1) For more information about traditional and new thermal metrics, see the *Semiconductor and IC Package Thermal Metrics* application report, [SPRA953](#).
- (2) The thermal data is based on JEDEC standard high K profile – JESD 51-7. The copper pad is soldered to the thermal land pattern. Also correct attachment procedure must be incorporated

6.5 Electrical Characteristics

V_I = 14 V, T_J = –40°C to +150°C, unless otherwise stated

PARAMETER		TEST CONDITIONS	MIN	TYP	MAX	UNIT
SUPPLY VOLTAGE AND CURRENT (IN)						
V _I	Input voltage		4.5		40	V
I _Q	Quiescent current	TPS7B7701-Q1: V _I = 4.5 to 40 V, V _(EN) ≥ 2 V, I _(OUT) = 0.1 mA		0.6	1	mA
		TPS7B7702-Q1: V _I = 4.5 to 40 V, V _(EN1) and V _(EN2) ≥ 2 V, I _(OUT1) and I _(OUT2) = 0.1 mA		0.6	1	
I _(shutdown)	Shutdown current	TPS7B7701-Q1: EN = GND			5	μA
		TPS7B7702-Q1: EN1 = EN2 = GND			5	
I _{nom}	Operating current	TPS7B7701-Q1: V _(EN) ≥ 2 V, I _(OUT) ≤ 300 mA, GND current			4.5	mA
		TPS7B7702-Q1: V _(EN1) and V _(EN2) ≥ 2 V, I _(OUT1) and I _(OUT2) ≤ 300 mA, GND current			6	
V _(BG)	Bandgap	Reference voltage for FB	–2%	1.233	2%	V
V _(UVLO)	Undervoltage lockout falling	Ramp IN down until the output turns off			4	V
V _{hys}	Hysteresis			0.4		V
INPUT CONTROL PINS (EN, EN1, EN2, SENSE_EN, AND SENSE_SEL)						
V _{IL}	Logic input low level	For EN, EN1, EN2, SENSE_EN, and SENSE_SEL	0		0.7	V
V _{IH}	Logic input high level	For EN, EN1, EN2, SENSE_EN, and SENSE_SEL	2			V
I _(SENSE_EN)	SENSE_EN input current	V _(SENSE_EN) = 5 V, V _(ENx) ≥ 2 V			10	μA
I _(SENSE_SEL)	SENSE_SEL input current	V _(SENSE_EN) = 5 V, V _(ENx) ≥ 2 V			10	μA
I _(EN)	Enable input current	V _(ENx) ≤ 40 V			10	μA
REGULATED OUTPUT (OUT, OUT1, AND OUT2)						
V _O	Regulated output	40 V ≥ V _I ≥ V _O + 1.5 V and V _I ≥ 4.5 V, I _O = 1 to 300 mA ⁽¹⁾	–2%		2%	
ΔV _{O(ΔVI)}	Line regulation	V _I = V _O + 1.5 V to 40 V and V _I ≥ 6 V, I _O = 10 mA, voltage variation on FB pin			10	mV
ΔV _{O(ΔIO)}	Load regulation	I _O = 1 mA to 200 mA, voltage variation on FB pin			20	mV
V _(DROPOUT)	Dropout voltage	Measured between IN and OUTx, I _O = 100 mA			500	mV
I _O	Output current	V _O in regulation	0		300	mA
PSRR	Power supply ripple rejection ⁽²⁾	I _O = 100 mA, C _O = 2.2 μF, f = 100 Hz		73		dB
CURRENT SENSE AND CURRENT-LIMIT						
I _O /I _{SENSE}	OUTx to SENSEx current ratio (I _O / I _{SENSEx})	V _I = 4.5 V to 40 V, 5 mA ≤ I _O ≤ 300 mA		198		

- (1) External feedback resistor is not considered.
- (2) Design information — not tested, ensured by characterization.

Electrical Characteristics (continued)

 $V_I = 14\text{ V}$, $T_J = -40^\circ\text{C}$ to $+150^\circ\text{C}$, unless otherwise stated

PARAMETER	TEST CONDITIONS	MIN	TYP	MAX	UNIT	
OUTx to SENSEx current ratio accuracy	$I_O = 100$ to 300 mA	-3%		3%		
	$I_O = 50$ to 100 mA	-5%		5%		
	$I_O = 10$ to 50 mA	-10%		10%		
	$I_O = 5$ to 10 mA	-20%		20%		
I_O/I_{LIM}	OUTx to LIMx current ratio (I_O / I_{LIM})	$V_I = 4.5\text{ V}$ to 40 V , $50\text{ mA} \leq I_{(LIMx)} \leq 300\text{ mA}$		198		
$I_{(LIMx)}$	Programmable current-limit accuracy ⁽³⁾	$V_I = 4.5\text{ V}$ to 40 V , $50\text{ mA} \leq I_{(LIMx)} \leq 300\text{ mA}$		-8%	8%	
$I_{L(LIMx)}$	Internal current-limit	LIMx shorted to GND		340	550	
I_{lkg}	SENSE, SENSE1, SENSE2, LIM, LIM1, and LIM2 leakage current	ENx = GND, $T_A = 25^\circ\text{C}$			2	
$V_{(LIMx_th)}$	Current-limit threshold voltage	Voltage on the LIM, LIM1, and LIM2 pins when output current is limited		1.233	V	
$V_{(SENSEx_stb)}$	Current-sense short-to-battery fault voltage	When short-to-battery or reverse current conditions are detected		3.05	3.2	3.3
$V_{(SENSEx_tsd)}$	Current-sense thermal shutdown fault voltage	When thermal shutdown is detected		2.7	2.85	3
$V_{(SENSEx_cl)}$	Current-sense current-limit fault voltage	When current-limit conditions are detected		2.4	2.55	2.65
$I_{(SENSEx_H)}$	Current-sense fault condition current	When short-to-battery, reverse current, thermal shutdown, or current-limit conditions are detected		3.3		mA
FAULT DETECTION						
$V_{(stb_th)}$	Short-to-battery threshold	$V_{(OUTx)} - V_I$, checked during turnon sequence		-500	-55	110
$I_{(REV)}$	Reverse current detection level	Power FET on (SW or LDO mode)		-100	-40	-1
T_{SD}	Thermal shutdown	Junction temperature			175	$^\circ\text{C}$
$T_{SD(hys)}$	Thermal shutdown hysteresis				15	$^\circ\text{C}$
INTERFACE CIRCUITRY						
V_{OL}	$\overline{\text{ERR}}$ output low	$I_{(SINK)} = 5\text{ mA}$			0.4	V
I_{lkg}	$\overline{\text{ERR}}$ open-drain leakage current	$\overline{\text{ERR}}$ high impedance, 5-V external voltage is applied at $\overline{\text{ERR}}$			1	μA
$R_{(OUTx_off)}$	OUT pulldown resistor ⁽²⁾	ENx = GND			50	k Ω
$I_{R(lkg)}$	Reverse leakage current	$-40\text{ V} < V_I < 0\text{ V}$, reverse current to IN			0.6	mA
V_{CC}	Internal voltage regulator	$V_I = 5.5$ to 40 V , $I_{CC} = 0\text{ mA}$		4.25	4.5	4.75
$I_{CC(lim)}$	Internal voltage-regulator current-limit			15		70

(3) The current-limit accuracy is ensured when the current limit is set between 50 mA and 300 mA, and it includes the deviation of the current-limit threshold voltage $V_{(LIMx_th)}$.

6.6 Switching Characteristics

PARAMETER	TEST CONDITIONS	MIN	TYP	MAX	UNIT	
CURRENT SENSE AND CURRENT-LIMIT						
$t_{d(SENSE_SEL_r)}$	Current-sense delay time from the rising edge of SENSE_SEL ⁽¹⁾	$V_{(ENx)} \geq 2\text{ V}$, $\overline{\text{SENSE_EN}} = \text{GND}$, SENSE_SEL rise from 0 to 5 V			10	μs
$t_{d(SENSE_SEL_f)}$	Current-sense delay time from the falling edge of SENSE_SEL ⁽¹⁾	$V_{(ENx)} \geq 2\text{ V}$, $\overline{\text{SENSE_EN}} = \text{GND}$, SENSE_SEL fall from 5 to 0 V			10	μs
$t_{d(SENSE_EN_r)}$	Current-sense delay time from rising edge of SENSE_EN ⁽¹⁾	$V_{(ENx)} \geq 2\text{ V}$, $\overline{\text{SENSE_EN}}$ rise from 0 to 5 V			10	μs
$t_{d(SENSE_EN_f)}$	Current-sense delay time from falling edge of SENSE_EN ⁽¹⁾	$V_{(ENx)} \geq 2\text{ V}$, $\overline{\text{SENSE_EN}}$ fall from 5 to 0 V			10	μs
FAULT DETECTION						
$t_{(PD_RC)}$	Reverse current (Short-to-BAT) shutdown deglitch time	Delay to shut down the switch or LDO after a drop over r_{on} becomes negative, $I_{(OUTx)} = -200\text{ mA}$ (typical), $T_A = 25^\circ\text{C}$			5	20
$t_{(BLK_RC)}$	Reverse current blanking time	Blanking time for reverse-current detection after power up, the rising edge of the ENx pin, or the current limiting event is over			16	ms

(1) Design information — not tested, ensured by characterization.

6.7 Typical Characteristics

$V_I = 14\text{ V}$, unless otherwise specified

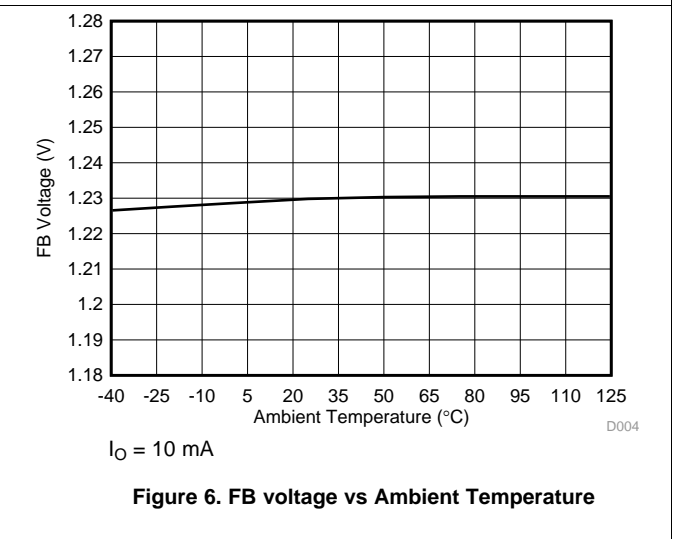
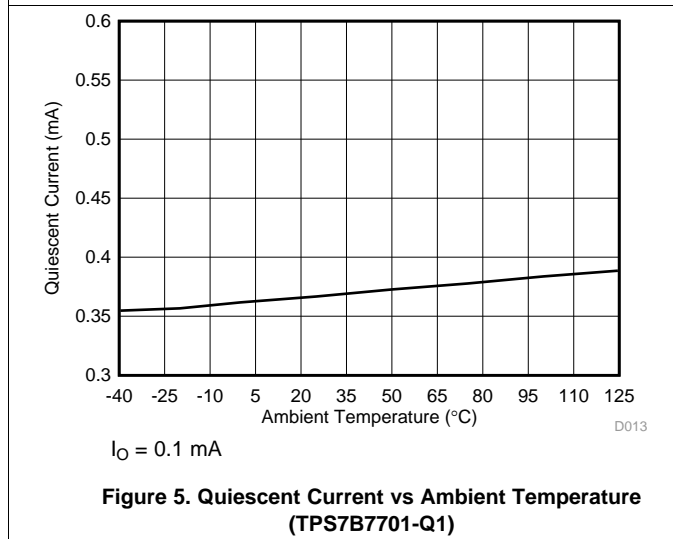
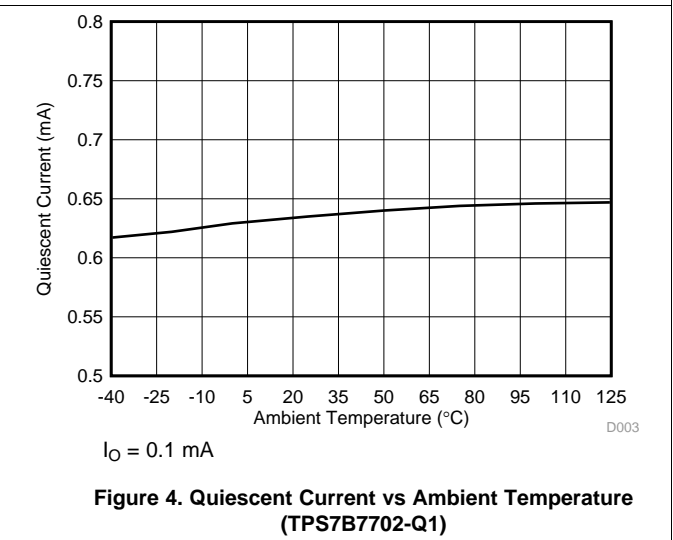
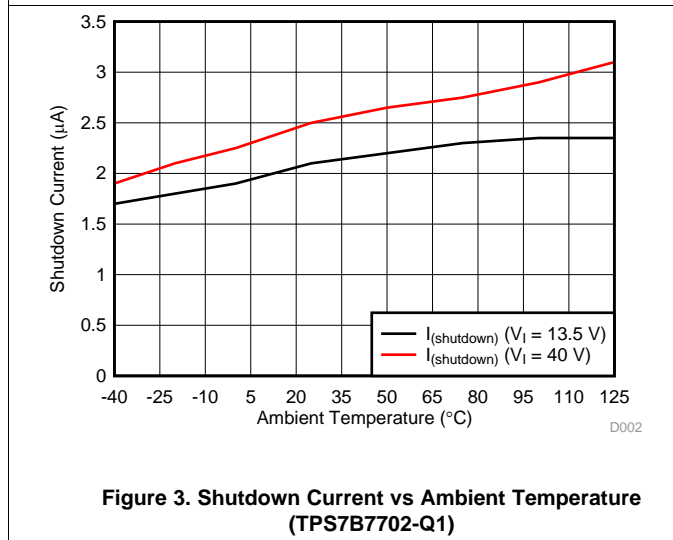
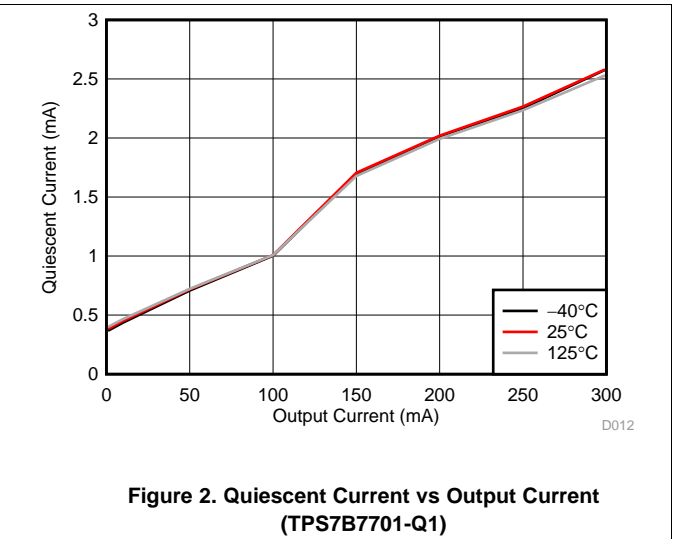
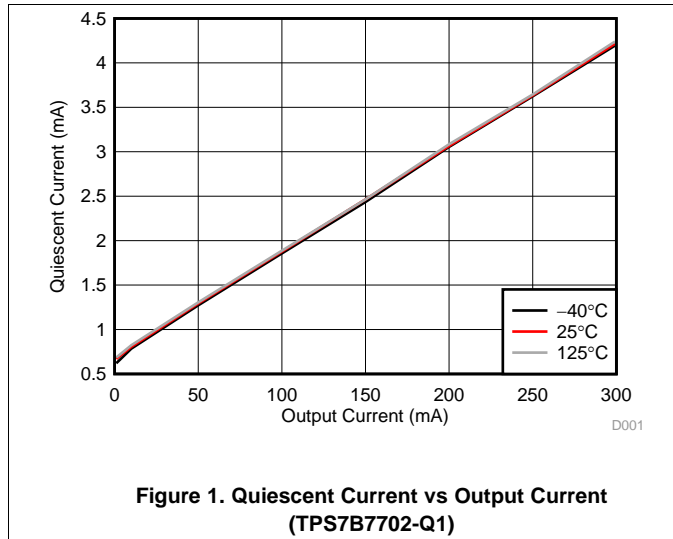

Typical Characteristics (continued)

$V_I = 14\text{ V}$, unless otherwise specified

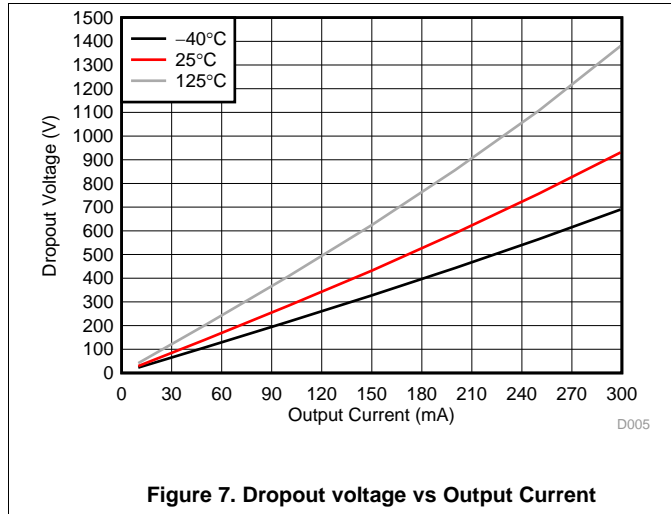

Figure 7. Dropout voltage vs Output Current

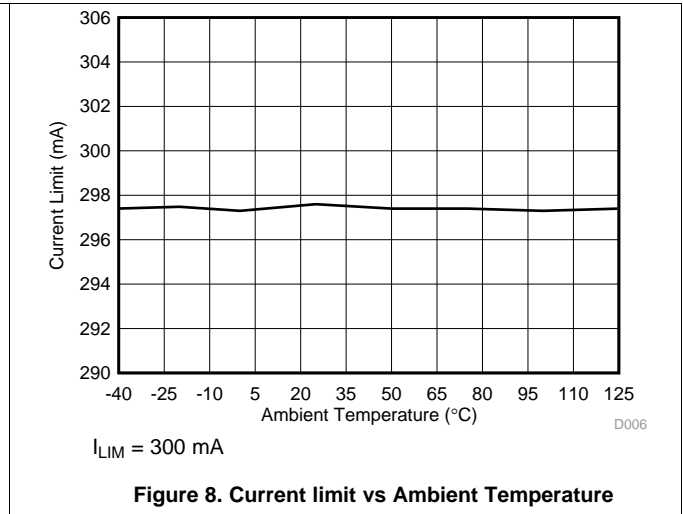

Figure 8. Current limit vs Ambient Temperature

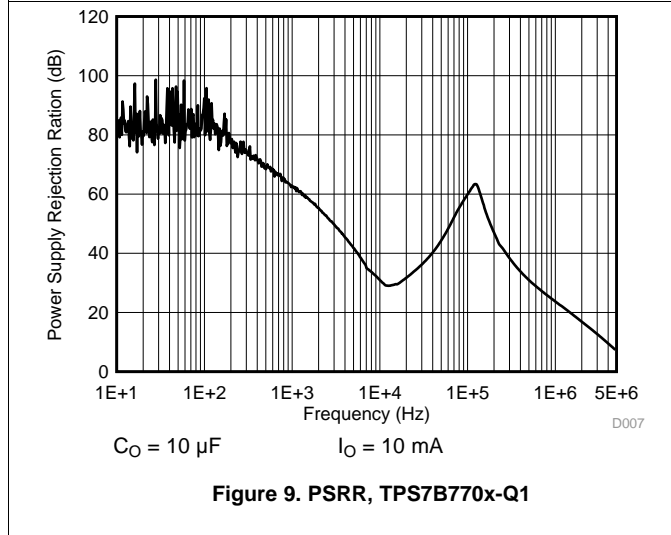

Figure 9. PSRR, TPS7B770x-Q1

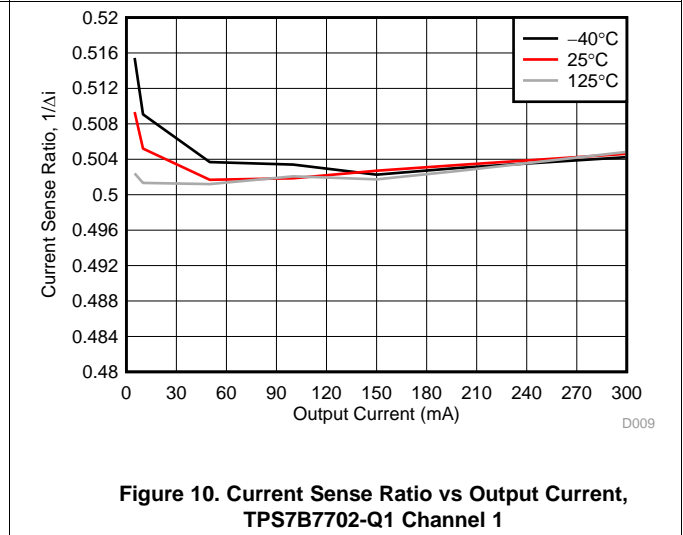

Figure 10. Current Sense Ratio vs Output Current, TPS7B7702-Q1 Channel 1

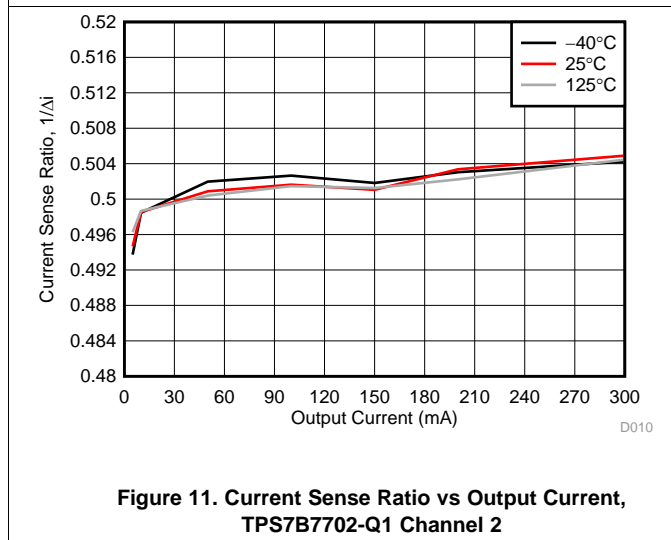

Figure 11. Current Sense Ratio vs Output Current, TPS7B7702-Q1 Channel 2

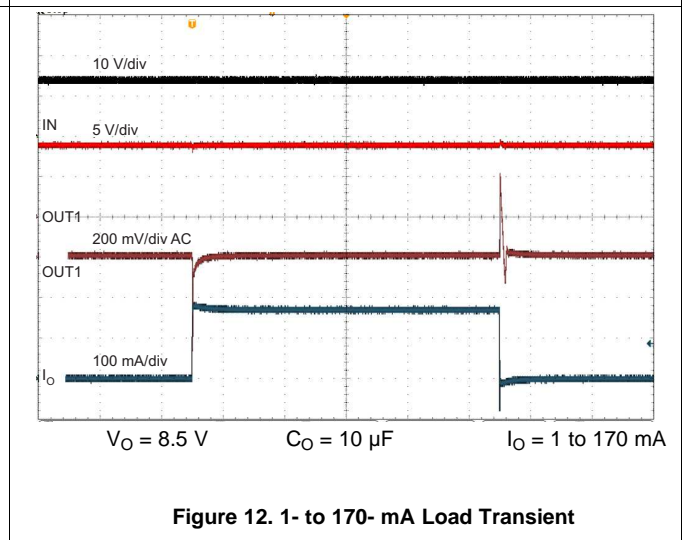

Figure 12. 1- to 170- mA Load Transient

Typical Characteristics (continued)

$V_I = 14\text{ V}$, unless otherwise specified

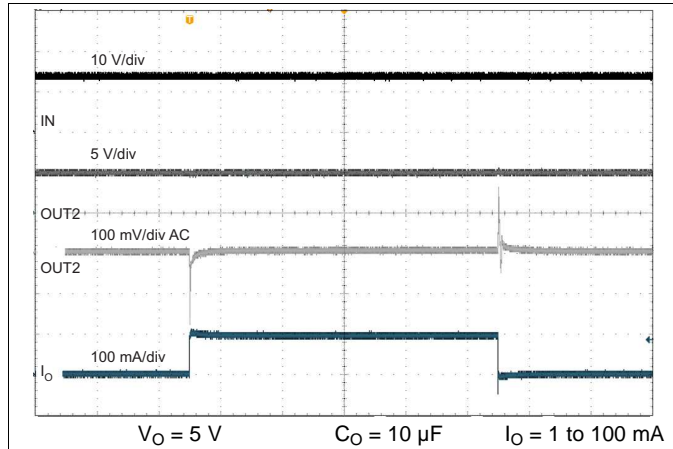

Figure 13. 1- to 100- mA Load Transient

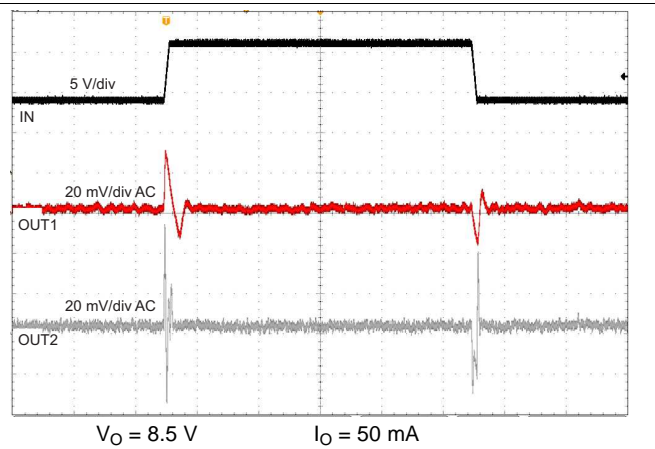

Figure 14. 9- to 16-V Line Transient (1 V/μs)

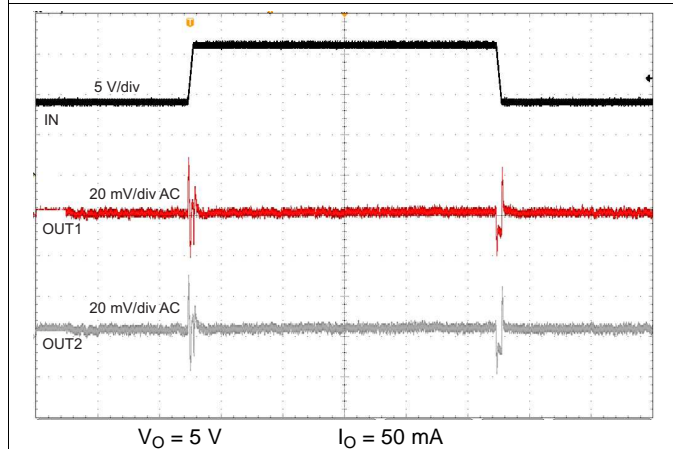

Figure 15. 9- to 16-V Line Transient (1 V/μs)

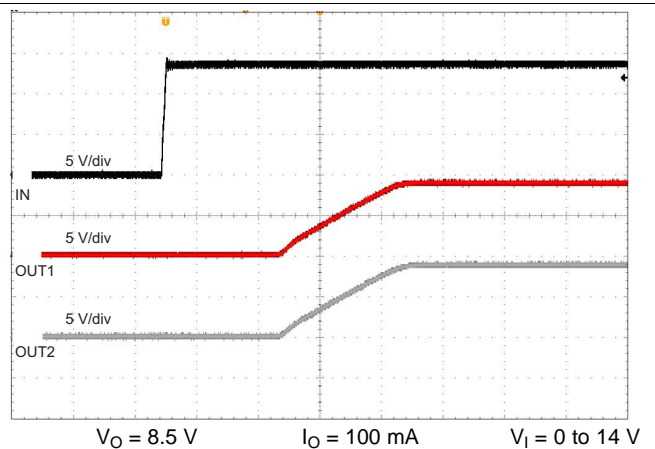

Figure 16. Power Up (1 V/μs)

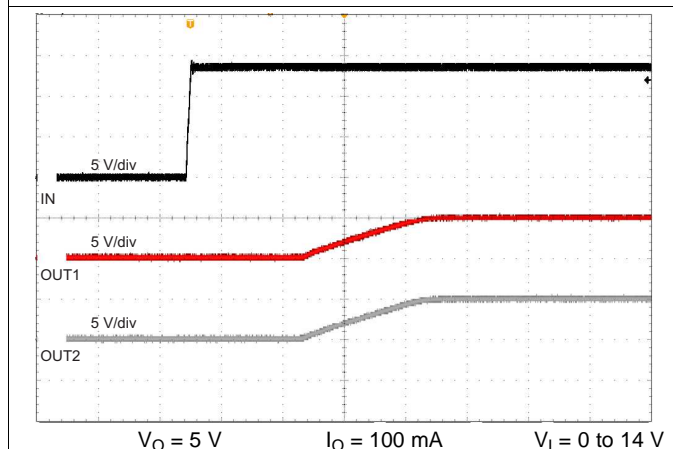

Figure 17. Power Up (1 V/μs)

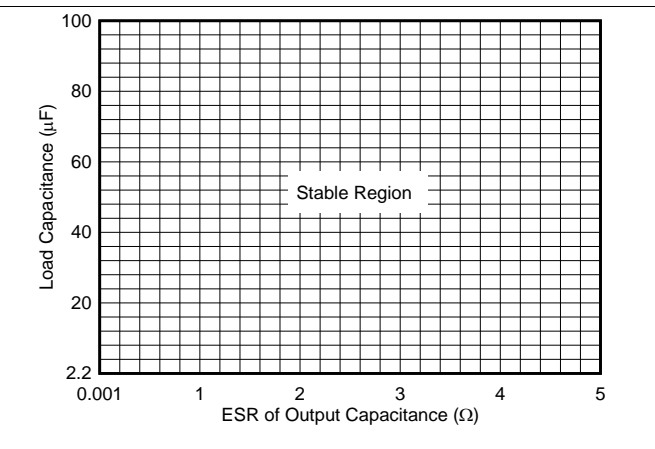

Figure 18. Load Capacitance vs ESR of Output Capacitance

7 Detailed Description

7.1 Overview

The TPS7B770x-Q1 family of devices is a single- or dual-channel high voltage LDO regulator with current-sense function. The device is designed to operate with a wide input-voltage range of 4.5 to 40 V (45-V load dump protection). It also offers protection of antenna lines against ESD and from short to ground, short to battery, and thermal overstress. The device output voltage is adjustable from 1.5 to 20 V through an external resistor divider. Alternatively, each channel can be configured as a switch.

The device monitors the load. Accurate current sense allows for detection of open, normal, and short-circuit conditions without the need of further calibration. The current sense can also be multiplexed between channels and devices to save ADC resources. Each channel also provides an adjustable current limit with external resistor.

7.2 Functional Block Diagram

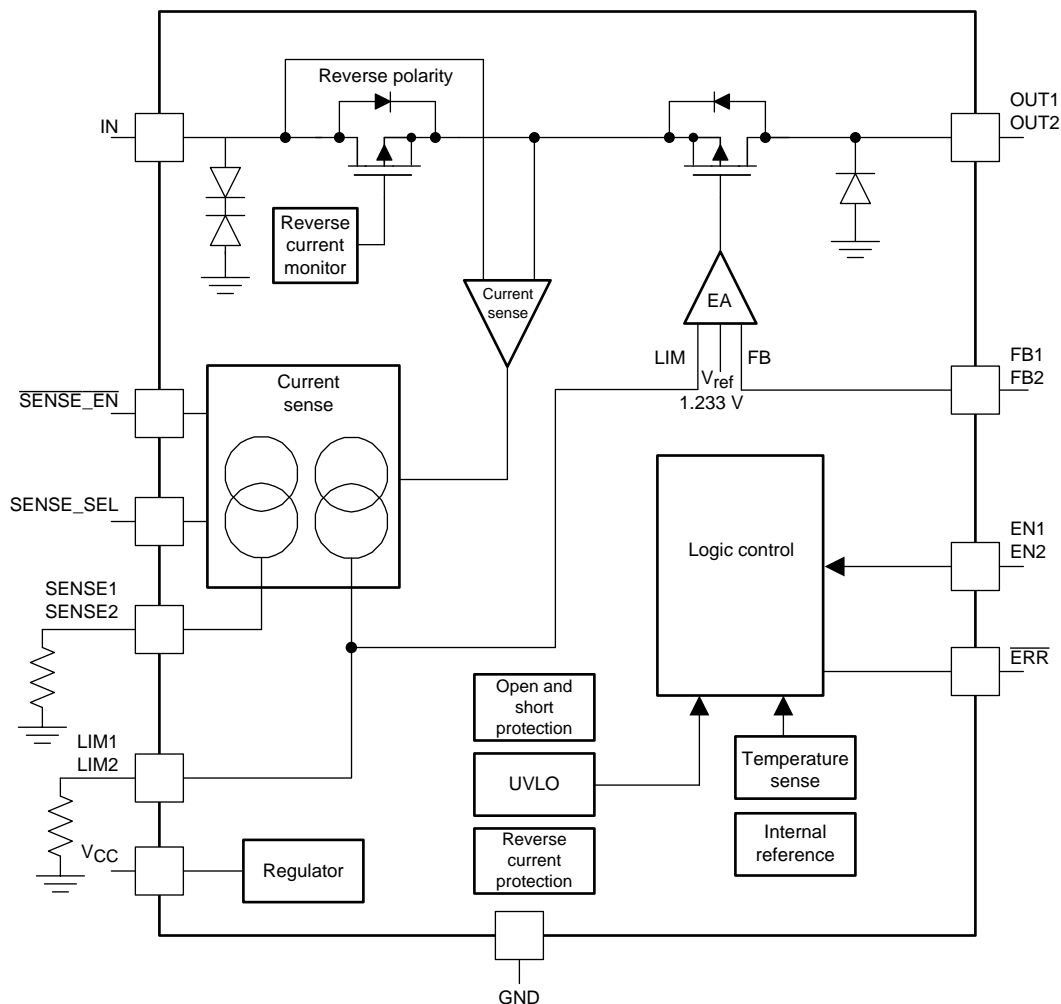

7.3 Feature Description

7.3.1 Fault Detection and Protection

The device includes both analog current sense and digital fault pins for full diagnostics of different fault conditions.

Feature Description (continued)

The current-sense voltage scale is selected based on the output-current range of interest. Figure 19 shows a recommended setting that allows for full diagnostics of each fault. Before the device goes into current-limit mode, the output current-sense voltage is linearly proportional to the actual load current. During a thermal-shutdown (TSD) and short-to-battery (STB) condition, the current-sense voltage is set to the fault voltage level that is specified in the [Electrical Characteristics](#) table.

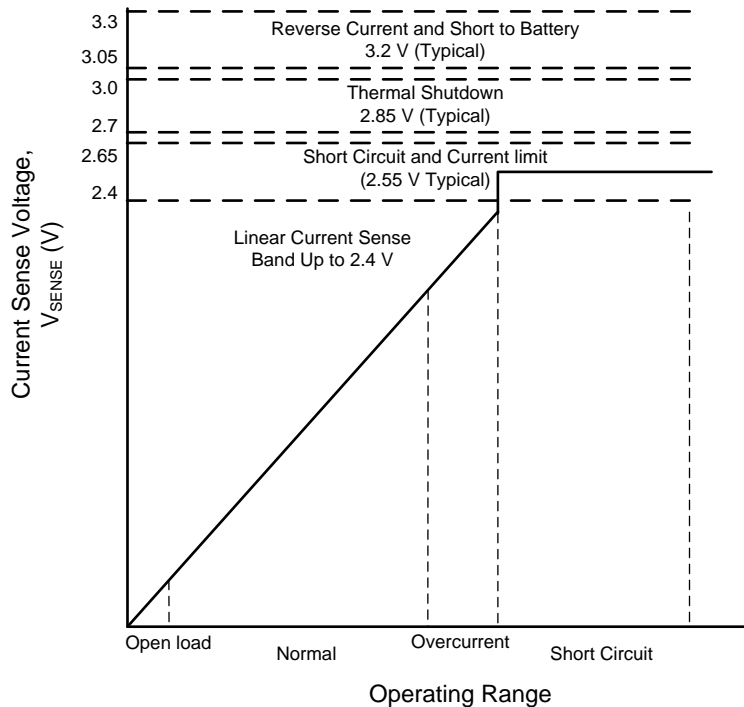

Figure 19. Functionality of the Current-Sense Output

7.3.2 Short-Circuit and Overcurrent Protection

The current limit on each channel is programmed by selecting the external resistor. The voltage on LIMx pin is compared with an internal voltage reference. When the threshold is exceeded, the current limit is triggered. The output of the current limited channel continues to remain on and the current is limited.

Under current-limit status, the \overline{ERR} pin asserts low and the SENSE voltage of the fault channel is internally pulled up to a voltage rail between 2.4 V and 2.65 V as shown in Figure 19. At this moment, the output voltage is not disabled. The microcontroller (MCU) should monitor the voltage at the SENSEx pin or \overline{ERR} pin to disable the faulted channel by pulling the \overline{ENx} pin low. If a current-limit condition exists for a long period of time, thermal shutdown can be triggered and shutdown the output.

7.3.3 Short-to-Battery and Reverse Current Detection

Shorting the OUT pin to the battery because of a fault in the system is possible. Each channel detects this failure by comparing the voltage at the OUT and IN pins before the switch turns on. Each time the LDO switch is enabled on the rising edge of the EN pin or during the exiting of the thermal shutdown, the short-to-battery detection occurs. At this moment, if the device detects the short-to-battery fault, the LDO switch is latched off, the \overline{ERR} pin is asserted low, and the fault-channel SENSE voltage is pulled up internally to a voltage rail between 3.05 V and 3.3 V. The device operates normally when the short-to-battery is removed and the EN pin is toggled.

During normal operation if a short-to-battery fault results in reverse current for more than 5 μ s (typical), the LDO switch is latched off and the \overline{ERR} pin is asserted low. To remove the latched condition after a short-to-battery (reverse current) fault, the condition must first be removed and then the EN pin must be toggled.

Feature Description (continued)

Series inductance and the output capacitor can produce ringing during power up or recovery from current limit, resulting in an output voltage that temporarily exceeds the input voltage. The 16-ms (typical) reverse-current blanking can help filter this ringing.

For the dual-channel antenna LDO application, if both channels are enabled and one channel is shorted to ground after power up, the current drawn from the input capacitor can result in a temporary dip in the input voltage, which can trigger the reverse-current detection fault. To avoid this false trigger event, care must be taken when selecting the input capacitor; an increase of the input capacitor value is recommended.

7.3.4 Thermal Shutdown

The device incorporates a TSD circuit as a protection from overheating. For continuous normal operation, the junction temperature should not exceed the TSD trip point. If the junction temperature exceeds the TSD trip point, the output is turned off. When the junction temperature decreases by 15°C (typical) than the TSD trip point, the output is turned on again. The SENSE voltage is internally pulled up to a voltage rail between 2.7 V and 3 V during TSD status.

NOTE

The purpose of the design of the internal protection circuitry of the TPS7B770x-Q1 family of devices is to protect against overload conditions and is not intended as a replacement for proper heat-sinking. Continuously running the device into thermal shutdown degrades device reliability.

7.3.5 Integrated Reverse-Polarity Protection

The device integrates a reverse-connected PMOS to block the reverse current during reverse polarity at the input and output short-to-battery condition. A special ESD structure at the input is ensured to withstand –40 V.

7.3.6 Integrated Inductive Clamp

During output turnoff, the cable inductance continues to source the current from the output of the device. The device integrates an inductive clamp to help dissipate the inductive energy stored in the cable. An internal diode is connected between OUT and GND pins with a DC-current capability of 300 mA for inductive clamp protection.

7.3.7 Undervoltage Lockout

The device includes an undervoltage lockout (UVLO) threshold that is internally fixed. The undervoltage lockout activates when the input voltage on the IN pin drops below $V_{(UVLO)}$. UVLO ensures the regulator is not latched into an unknown state during low input-supply voltage. If the input voltage has a negative transient that drops below the UVLO threshold and then recovers, the regulator shuts down and powers up with a normal power-up sequence when the input voltage is above the required levels.

Table 1. Fault Table

FAILURE MODE	$V_{(SENSE)}$	\overline{ERR}	LDO SWITCH OUTPUT	LATCHED
Open load	$I_O \times R_{(SENSE)}$ 198	HIGH	Enabled	No
Normal		HIGH	Enabled	No
Overcurrent		HIGH	Enabled	No
Short-circuit or current limit	2.4 to 2.65 V	LOW	Enabled	No
Thermal shutdown	2.7 to 3 V	LOW	Disabled	No
Output short-to-battery	3.05 to 3.3 V	LOW	Disabled	Yes
Reverse current	3.05 to 3.3 V	LOW	Disabled	Yes

7.3.8 Enable (EN, EN1, and EN2)

The TPS7B7702-Q1 device features two active-high enable inputs, EN1 and EN2. The EN1 pin controls output voltage 1, OUT1, and the EN2 pin controls output voltage 2, OUT2. The device consumes a maximum of shutdown current 5- μ A when the ENx pins are low. Both the EN1 and EN2 pins have a maximum internal pulldown of 10 μ A.

The TPS7B7701-Q1 device features one active-high enable input. The device consumes a maximum shutdown current of 5 μ A when the EN pin is low. The EN pin has a maximum internal pull down of 10 μ A.

7.3.9 Internal Voltage Regulator (V_{CC})

The device features an internal regulator that regulates the input voltage to 4.5 V to power all internal circuitry. Bypass a 1- μ F ceramic capacitor from the V_{CC} pin to the GND pin for frequency compensation. The V_{CC} pin can be used as a power supply for external circuitry with up to 15-mA current capability.

7.3.10 Current Sense Multiplexing

The two, independent current sense pins (one for each channel) provide flexibility in the system design. When the ADC resource is limited, the device allows the multiplexing of the current sense pins by only using one current sense pin and one ADC to monitor all the antenna outputs.

The SENSE_SEL pin (TPS7B7702-Q1 only) selects the channels to monitor the current. The $\overline{\text{SENSE_EN}}$ pin enables and disables the SENSE pin, allowing multiplexing between chips. Therefore, only one ADC and one resistor is needed for current-sense diagnostics of multiple outputs. When the SENSE1 pin is connected to an ADC, the current flow through both channels can be sensed by changing the electrical level at the SENSE_SEL pin.

Table 2 lists the selection logic for the current sense.

Table 2. $\overline{\text{SENSE_EN}}$ and SEN_SEL Logic Table

$\overline{\text{SENSE_EN}}$	SEN_SEL	SENSE1 Status	SENSE2 Status
LOW	LOW	CH1 current	CH2 current
LOW	HIGH	CH2 current	HIGH impedance
HIGH	—	HIGH impedance	HIGH impedance

Figure 20 shows the application of four antenna channels sharing one ADC resource.

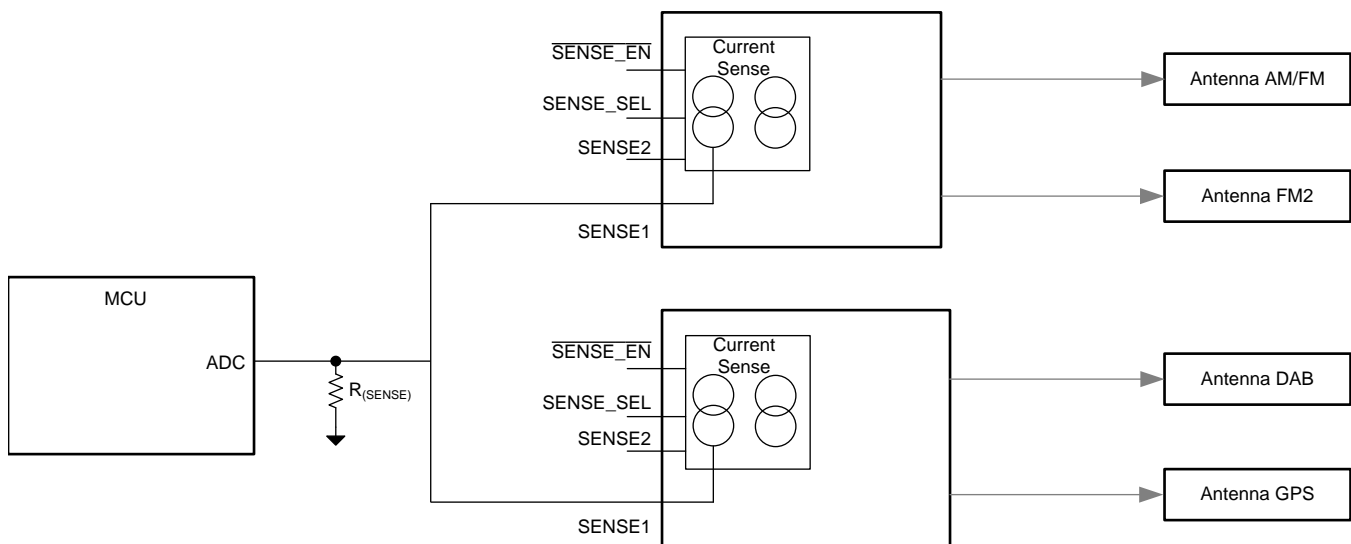

Figure 20. Current Multiplexing Application Block

7.3.11 Adjustable Output Voltage (FB, FB1, and FB2)

Using an external resistor divider selects an output voltage between 1.5 V and 20 V. Use [Table 2](#) to calculate the output voltage (V_O). The recommended value for both R1 and R2 is less than 100 k Ω .

$$V_O = \frac{V_{(FB)} \times (R1 + R2)}{R2}$$

where

- $V_{(FB)} = 1.233 \text{ V}$

(1)

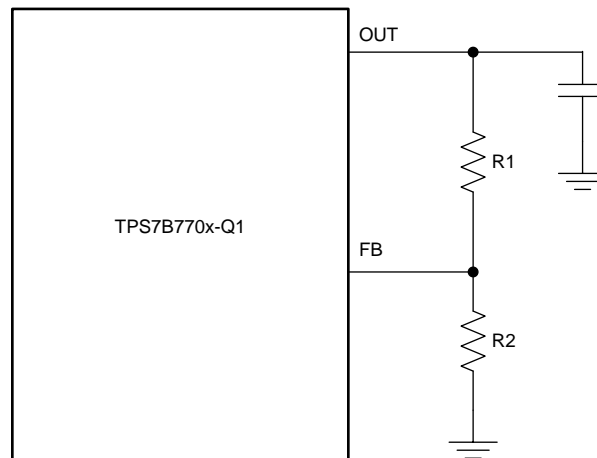

Figure 21. TPS7B770x Output Voltage Setting Connection

The TPS7B770x-Q1 family of devices can also be used as a current-limited switch by connecting the FB pin to the GND pin.

7.4 Device Functional Modes

7.4.1 Operation With $IN < 4.5 \text{ V}$

The maximum UVLO voltage is 4 V and the device operates at an input voltage above 4.5V. The device can also operate at lower input voltage. No minimum UVLO voltage is specified. At an input voltage below the actual UVLO voltage, the device does not operate.

7.4.2 Operation With EN Control

The threshold of EN rising edge is 2 V (maximum). With the EN pin held above that voltage and the input voltage above 4.5 V, the device becomes active. The EN falling edge is 0.7 V (minimum). Holding the EN pin below that voltage disables the device which therefore reduces the quiescent current of the device.

8 Application and Implementation

NOTE

Information in the following applications sections is not part of the TI component specification, and TI does not warrant its accuracy or completeness. TI's customers are responsible for determining suitability of components for their purposes. Customers should validate and test their design implementation to confirm system functionality.

8.1 Application Information

The TPS7B770x-Q1 family of devices is a single- or dual-channel 300-mA LDO regulator with high, accurate current sense and a programmable current-limit function. Use the PSPICE transient model to evaluate the base function of the devices. Go to www.ti.com to download the PSPICE model and user's guide for the devices.

8.2 Typical Application

Figure 22 shows the typical application circuit for the TPS7B770x-Q1 family of devices. Different values of external components can be used depending on the end application. An application can require a larger output capacitor during fast load steps to prevent large drops on output voltage. TI recommends a low-ESR ceramic capacitor with a dielectric of type X5R or X7R.

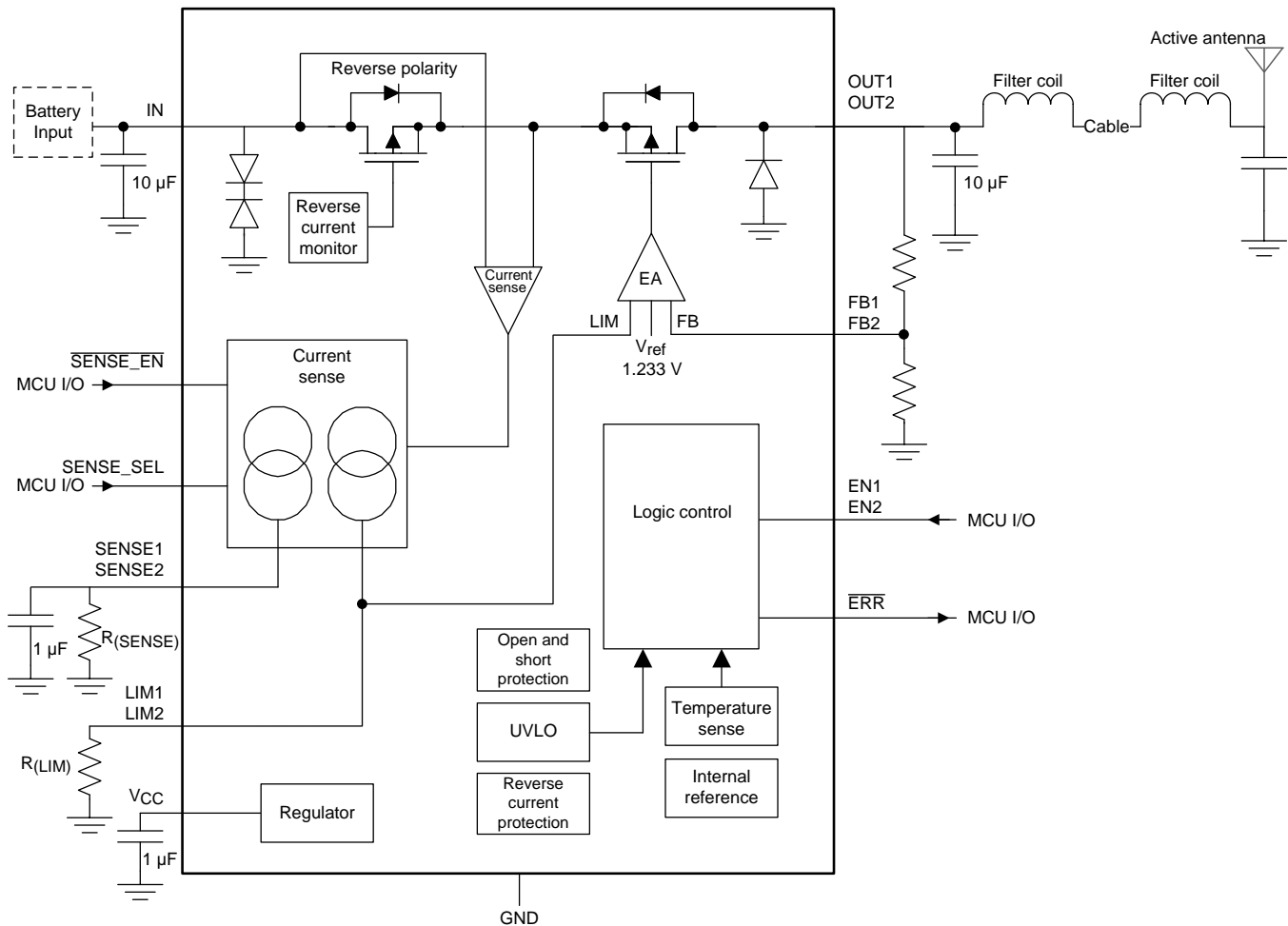

Figure 22. TPS7B770x Typical Application

Typical Application (continued)

8.2.1 Design Requirements

For this design example, use the parameters listed in [Table 3](#) as the design parameters.

Table 3. Design Parameters

DESIGN PARAMETER	EXAMPLE VALUE
Input voltage range	4.5 to 40 V
Output voltage	1.5 to 20 V
Output capacitor range	2.2 to 100 μ F
Output Capacitor ESR range	0.001 to 5 Ω
SENSE resistor	See the Current Sense Resistor Selection section
Programmable current limit	50 to 300 mA

8.2.2 Detailed Design Procedure

To begin the design process, determine the following:

- Input voltage
- Output voltage
- Output current
- Current limit
- ADC voltage rating

8.2.2.1 Input Capacitor

The device requires an input decoupling capacitor, the value of which depends on the application. The typical recommended value for the decoupling capacitor is 10 μ F. The voltage rating must be greater than the maximum input voltage.

8.2.2.2 Output Capacitor

The device requires an output capacitor to stabilize the output voltage. The capacitor value should be between 2.2 μ F and 100 μ F. The ESR range should be between 1 m Ω and 5 Ω . TI recommends selecting a ceramic capacitor with low ESR to improve the load transient response.

8.2.2.3 Current Sense Resistor Selection

The current-sense outputs, SENSE_x (SENSE, SENSE1, and SENSE2), are proportional to the output current at the OUT, OUT1, and OUT2 pins with a factor of 1/198. An output resistor, R_(SENSE_x), must be connected between the SENSE_x pin and ground to generate a current sense voltage to be sampled by ADC. Use [Equation 2](#) to calculate the voltage at SENSE_x pin ($V_{(SENSEx)}$).

$$V_{(SENSEx)} = I_{(SENSEx)} \times R_{(SENSEx)}$$

where

$$I_{(SENSEx)} = \frac{I_{(OUTx)}}{198} \quad (2)$$

For this example, select 1.5 k Ω as a value for R_(SENSE_x). Do not consider the resistor and current-sense accuracy.

For a load current of 198 mA, use [Equation 3](#) to calculate the value of $V_{(SENSEx)}$.

$$I_{(SENSEx)} = \frac{198 \text{ mA}}{198} = 1 \text{ mA} \rightarrow V_{(SENSEx)} = 1 \text{ mA} \times 1.5 \text{ k}\Omega = 1.5 \text{ V} \quad (3)$$

To avoid any overlap between normal operation and current-limit or short-to-ground phase, using [Equation 4](#) to select the value of the SENSE resistor is recommended.

$$R_{(\text{SENSE}x)} \leq \frac{198 \times 2.4 \text{ V}}{I_{\text{Omax}}}$$

where

- 198 is the output current to current-sense ratio
- 2.4 V is the minimum possible voltage at the SENSE_x pin under a short-circuit fault case
- I_{Omax} is the maximum possible output current under normal operation (4)

To stabilize the current-sense loop, connecting a 1- μF ceramic capacitor at the SENSE, SENSE1, or SENSE2 pin is required. [Table 4](#) lists the current sense accuracy across temperature.

Table 4. Current Sense Accuracy

OUTPUT CURRENT	CURRENT SENSE ACCURACY
5 to 10 mA	20%
10 to 50 mA	10%
50 to 100 mA	5%
100 to 300 mA	3%

8.2.2.4 Current-Limit Resistor Selection

The current at the LIM_x pins (LIM, LIM1, and LIM2) is proportional to the load current at the OUT_x (OUT, OUT1, and OUT2) pins and is internally connected to a current-limit comparator referenced to 1.233 V. The current limit is programmable through the external resistor connected at LIM_x pin. Use [Equation 5](#) to calculate the value of the external resistor, $R_{(\text{LIM}x)}$.

$$R_{(\text{LIM}x)} = \frac{1.233 \text{ V}}{I_{(\text{LIM}x)}} \times 198$$

where

$$I_{(\text{LIM}x)} = \frac{1.233 \text{ V}}{R_{(\text{LIM}x)}} \times 198 \quad (5)$$

Select a current-limit value of 200 mA and use [Equation 6](#) to calculate the value of $R_{(\text{LIM}x)}$.

$$R_{(\text{LIM}x)} = \frac{1.233 \text{ V}}{0.2} \times 198 = 1220 \ \Omega \quad (6)$$

The programmable current limit accuracy is 8% maximum across all conditions. The internal current limit of the device is set by shorting the LIM pin to ground.

8.2.3 Application Curves

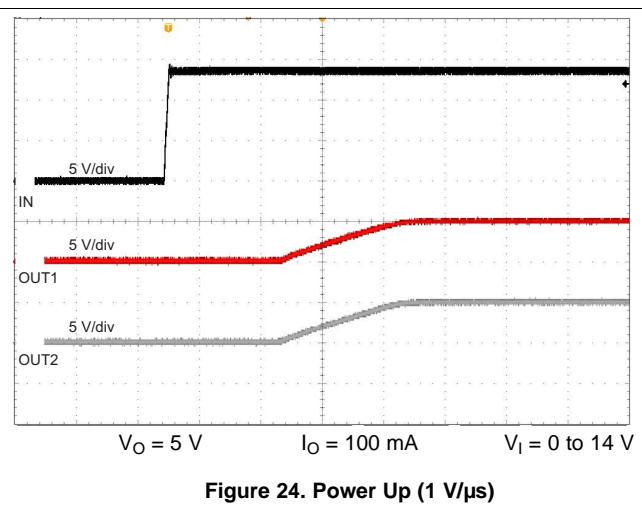
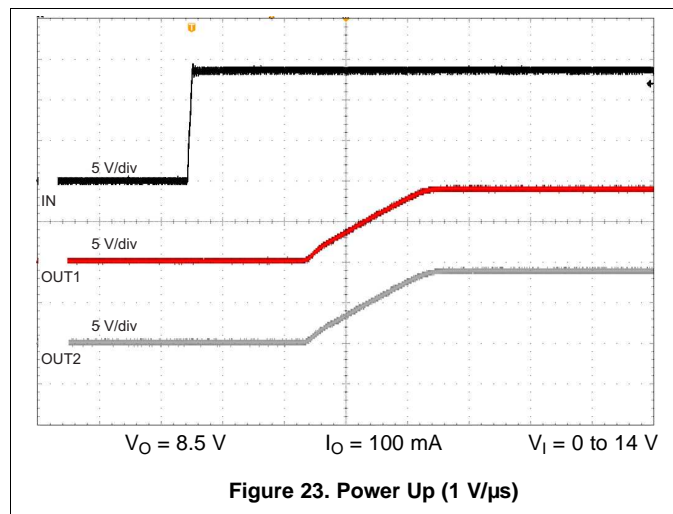

9 Power Supply Recommendations

The device is designed to operate from an input voltage supply with a range between 4.5 V and 40 V. This input supply must be well regulated. If the input supply is located more than a few inches from the TPS7B770x-Q1 device, TI recommends adding an 10-μF electrolytic capacitor and a ceramic bypass capacitor at the input.

10 Layout

10.1 Layout Guidelines

For the layout of TPS7B770x-Q1 device, place the input and output capacitors close to the device as shown in [Figure 25](#). To enhance the thermal performance, TI recommends surrounding the device with some vias.

Minimize equivalent-series inductance (ESL) and ESR to maximize performance and ensure stability. Place every capacitor as close as possible to the device and on the same side of the PCB as the regulator.

Do not place any of the capacitors on the opposite side of the PCB from where the regulator is installed. TI strongly discourages the use long traces because they can negatively impact system performance and cause instability.

If possible, and to ensure the maximum performance specified in this device data sheet, use the same layout pattern used for the TPS7B770x-Q1 evaluation board which is available online at www.ti.com/tool/TPS7B7702-Q1EVM.

10.2 Layout Example

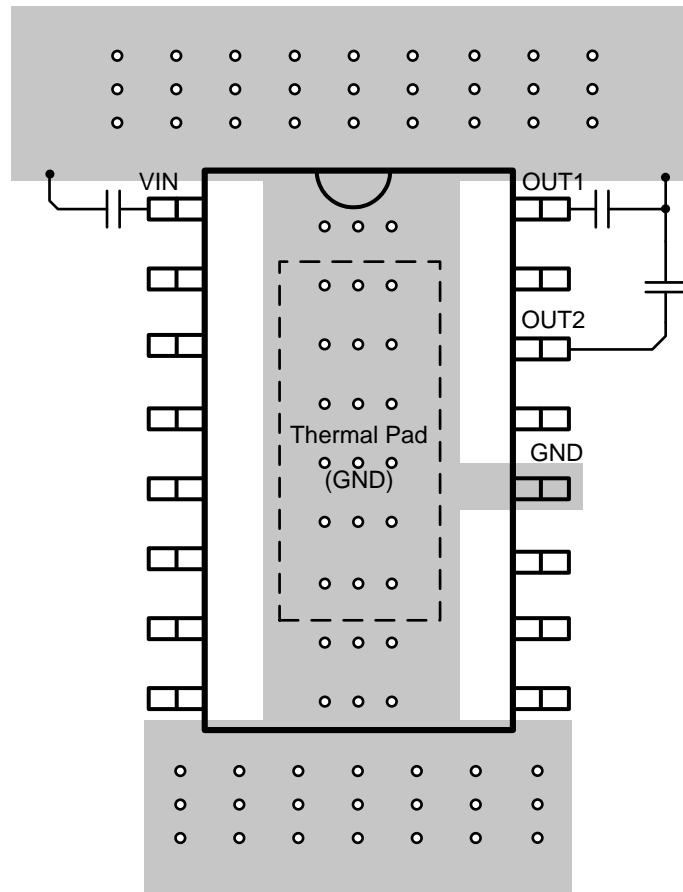

Figure 25. TPS7B770x Layout Example

11 Device and Documentation Support

11.1 Documentation Support

11.1.1 Related Documentation

For related documentation see the following:

TPS7B7702-Q1 Evaluation Module, [SLVUAE9](#)

11.2 Related Links

The table below lists quick access links. Categories include technical documents, support and community resources, tools and software, and quick access to sample or buy.

Table 5. Related Links

PARTS	PRODUCT FOLDER	SAMPLE & BUY	TECHNICAL DOCUMENTS	TOOLS & SOFTWARE	SUPPORT & COMMUNITY
TPS7B7701-Q1	Click here	Click here	Click here	Click here	Click here
TPS7B7702-Q1	Click here	Click here	Click here	Click here	Click here

11.3 Community Resource

The following links connect to TI community resources. Linked contents are provided "AS IS" by the respective contributors. They do not constitute TI specifications and do not necessarily reflect TI's views; see TI's [Terms of Use](#).

TI E2E™ Online Community *TI's Engineer-to-Engineer (E2E) Community*. Created to foster collaboration among engineers. At e2e.ti.com, you can ask questions, share knowledge, explore ideas and help solve problems with fellow engineers.

Design Support *TI's Design Support* Quickly find helpful E2E forums along with design support tools and contact information for technical support.

11.4 Trademarks

PowerPad, E2E are trademarks of Texas Instruments.
All other trademarks are the property of their respective owners.

11.5 Electrostatic Discharge Caution



These devices have limited built-in ESD protection. The leads should be shorted together or the device placed in conductive foam during storage or handling to prevent electrostatic damage to the MOS gates.

11.6 Glossary

[SLYZ022](#) — *TI Glossary*.

This glossary lists and explains terms, acronyms, and definitions.

12 Mechanical, Packaging, and Orderable Information

The following pages include mechanical, packaging, and orderable information. This information is the most current data available for the designated devices. This data is subject to change without notice and revision of this document. For browser-based versions of this data sheet, refer to the left-hand navigation.

PACKAGING INFORMATION

Orderable Device	Status (1)	Package Type	Package Drawing	Pins	Package Qty	Eco Plan (2)	Lead/Ball Finish (6)	MSL Peak Temp (3)	Op Temp (°C)	Device Marking (4/5)	Samples
TPS7B7701QPWPRQ1	PREVIEW	HTSSOP	PWP	16	2000	Green (RoHS & no Sb/Br)	CU NIPDAU	Level-3-260C-168 HR	-40 to 125	7B7701	
TPS7B7702QPWPRQ1	ACTIVE	HTSSOP	PWP	16	2000	Green (RoHS & no Sb/Br)	CU NIPDAU	Level-3-260C-168 HR	-40 to 125	7B7702	Samples

(1) The marketing status values are defined as follows:

ACTIVE: Product device recommended for new designs.

LIFEBUY: TI has announced that the device will be discontinued, and a lifetime-buy period is in effect.

NRND: Not recommended for new designs. Device is in production to support existing customers, but TI does not recommend using this part in a new design.

PREVIEW: Device has been announced but is not in production. Samples may or may not be available.

OBSOLETE: TI has discontinued the production of the device.

(2) Eco Plan - The planned eco-friendly classification: Pb-Free (RoHS), Pb-Free (RoHS Exempt), or Green (RoHS & no Sb/Br) - please check <http://www.ti.com/productcontent> for the latest availability information and additional product content details.

TBD: The Pb-Free/Green conversion plan has not been defined.

Pb-Free (RoHS): TI's terms "Lead-Free" or "Pb-Free" mean semiconductor products that are compatible with the current RoHS requirements for all 6 substances, including the requirement that lead not exceed 0.1% by weight in homogeneous materials. Where designed to be soldered at high temperatures, TI Pb-Free products are suitable for use in specified lead-free processes.

Pb-Free (RoHS Exempt): This component has a RoHS exemption for either 1) lead-based flip-chip solder bumps used between the die and package, or 2) lead-based die adhesive used between the die and leadframe. The component is otherwise considered Pb-Free (RoHS compatible) as defined above.

Green (RoHS & no Sb/Br): TI defines "Green" to mean Pb-Free (RoHS compatible), and free of Bromine (Br) and Antimony (Sb) based flame retardants (Br or Sb do not exceed 0.1% by weight in homogeneous material)

(3) MSL, Peak Temp. - The Moisture Sensitivity Level rating according to the JEDEC industry standard classifications, and peak solder temperature.

(4) There may be additional marking, which relates to the logo, the lot trace code information, or the environmental category on the device.

(5) Multiple Device Markings will be inside parentheses. Only one Device Marking contained in parentheses and separated by a "~" will appear on a device. If a line is indented then it is a continuation of the previous line and the two combined represent the entire Device Marking for that device.

(6) Lead/Ball Finish - Orderable Devices may have multiple material finish options. Finish options are separated by a vertical ruled line. Lead/Ball Finish values may wrap to two lines if the finish value exceeds the maximum column width.

Important Information and Disclaimer: The information provided on this page represents TI's knowledge and belief as of the date that it is provided. TI bases its knowledge and belief on information provided by third parties, and makes no representation or warranty as to the accuracy of such information. Efforts are underway to better integrate information from third parties. TI has taken and continues to take reasonable steps to provide representative and accurate information but may not have conducted destructive testing or chemical analysis on incoming materials and chemicals. TI and TI suppliers consider certain information to be proprietary, and thus CAS numbers and other limited information may not be available for release.

In no event shall TI's liability arising out of such information exceed the total purchase price of the TI part(s) at issue in this document sold by TI to Customer on an annual basis.

TAPE AND REEL INFORMATION



QUADRANT ASSIGNMENTS FOR PIN 1 ORIENTATION IN TAPE



*All dimensions are nominal

Device	Package Type	Package Drawing	Pins	SPQ	Reel Diameter (mm)	Reel Width W1 (mm)	A0 (mm)	B0 (mm)	K0 (mm)	P1 (mm)	W (mm)	Pin1 Quadrant
TPS7B7702QPWPRQ1	HTSSOP	PWP	16	2000	330.0	12.4	6.9	5.6	1.6	8.0	12.0	Q1

TAPE AND REEL BOX DIMENSIONS



*All dimensions are nominal

Device	Package Type	Package Drawing	Pins	SPQ	Length (mm)	Width (mm)	Height (mm)
TPS7B7702QPWPRQ1	HTSSOP	PWP	16	2000	367.0	367.0	35.0

PWP (R-PDSO-G16)

PowerPAD™ PLASTIC SMALL OUTLINE

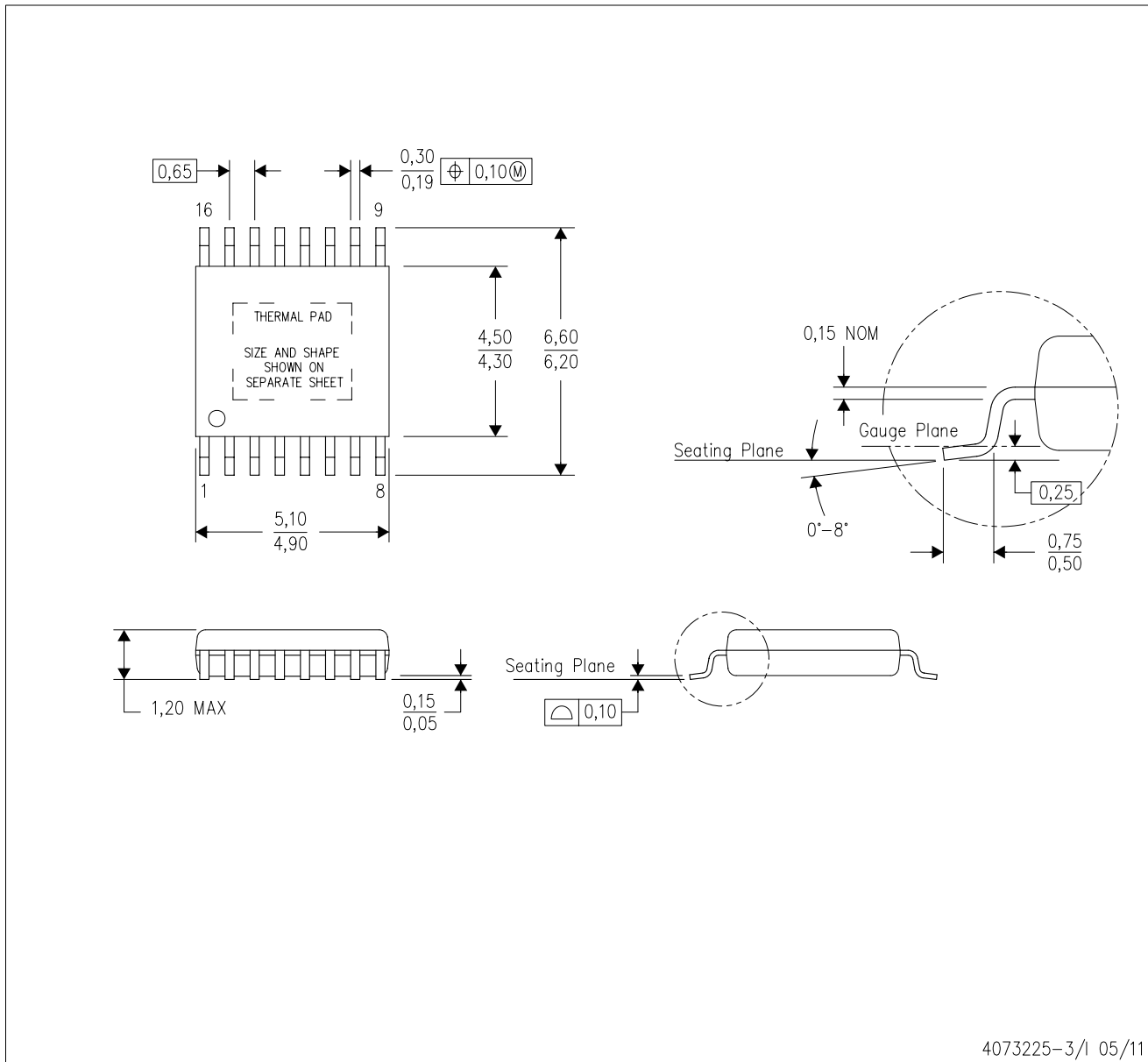

4073225-3/1 05/11

- NOTES:
- A. All linear dimensions are in millimeters.
 - B. This drawing is subject to change without notice.
 - C. Body dimensions do not include mold flash or protrusions. Mold flash and protrusion shall not exceed 0.15 per side.
 - D. This package is designed to be soldered to a thermal pad on the board. Refer to Technical Brief, PowerPad Thermally Enhanced Package, Texas Instruments Literature No. SLMA002 for information regarding recommended board layout. This document is available at www.ti.com <<http://www.ti.com>>.
 - E. See the additional figure in the Product Data Sheet for details regarding the exposed thermal pad features and dimensions.
 - E. Falls within JEDEC MO-153

PowerPAD is a trademark of Texas Instruments.

PWP (R-PDSO-G16) PowerPAD™ SMALL PLASTIC OUTLINE

THERMAL INFORMATION

This PowerPAD™ package incorporates an exposed thermal pad that is designed to be attached to a printed circuit board (PCB). The thermal pad must be soldered directly to the PCB. After soldering, the PCB can be used as a heatsink. In addition, through the use of thermal vias, the thermal pad can be attached directly to the appropriate copper plane shown in the electrical schematic for the device, or alternatively, can be attached to a special heatsink structure designed into the PCB. This design optimizes the heat transfer from the integrated circuit (IC).

For additional information on the PowerPAD package and how to take advantage of its heat dissipating abilities, refer to Technical Brief, PowerPAD Thermally Enhanced Package, Texas Instruments Literature No. SLMA002 and Application Brief, PowerPAD Made Easy, Texas Instruments Literature No. SLMA004. Both documents are available at www.ti.com.

The exposed thermal pad dimensions for this package are shown in the following illustration.

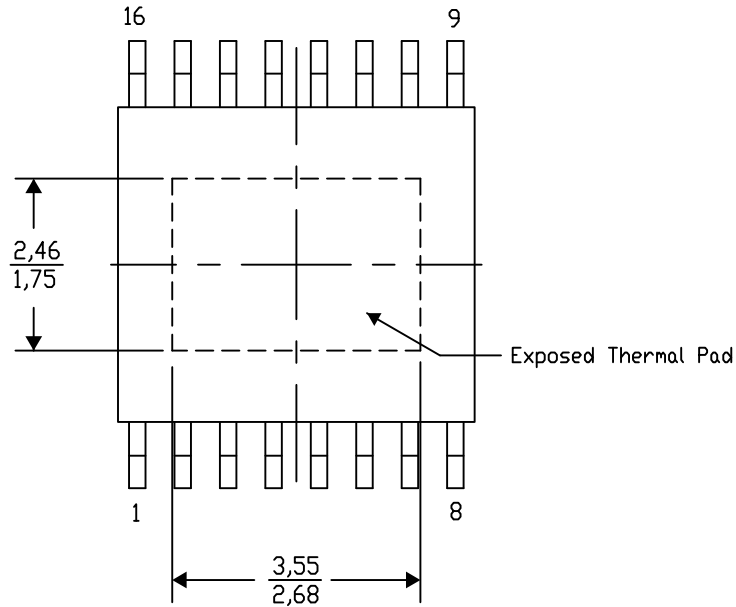

Top View

Exposed Thermal Pad Dimensions

4206332-51/AN 10/15

NOTE: A. All linear dimensions are in millimeters

PowerPAD is a trademark of Texas Instruments

IMPORTANT NOTICE

Texas Instruments Incorporated and its subsidiaries (TI) reserve the right to make corrections, enhancements, improvements and other changes to its semiconductor products and services per JESD46, latest issue, and to discontinue any product or service per JESD48, latest issue. Buyers should obtain the latest relevant information before placing orders and should verify that such information is current and complete. All semiconductor products (also referred to herein as "components") are sold subject to TI's terms and conditions of sale supplied at the time of order acknowledgment.

TI warrants performance of its components to the specifications applicable at the time of sale, in accordance with the warranty in TI's terms and conditions of sale of semiconductor products. Testing and other quality control techniques are used to the extent TI deems necessary to support this warranty. Except where mandated by applicable law, testing of all parameters of each component is not necessarily performed.

TI assumes no liability for applications assistance or the design of Buyers' products. Buyers are responsible for their products and applications using TI components. To minimize the risks associated with Buyers' products and applications, Buyers should provide adequate design and operating safeguards.

TI does not warrant or represent that any license, either express or implied, is granted under any patent right, copyright, mask work right, or other intellectual property right relating to any combination, machine, or process in which TI components or services are used. Information published by TI regarding third-party products or services does not constitute a license to use such products or services or a warranty or endorsement thereof. Use of such information may require a license from a third party under the patents or other intellectual property of the third party, or a license from TI under the patents or other intellectual property of TI.

Reproduction of significant portions of TI information in TI data books or data sheets is permissible only if reproduction is without alteration and is accompanied by all associated warranties, conditions, limitations, and notices. TI is not responsible or liable for such altered documentation. Information of third parties may be subject to additional restrictions.

Resale of TI components or services with statements different from or beyond the parameters stated by TI for that component or service voids all express and any implied warranties for the associated TI component or service and is an unfair and deceptive business practice. TI is not responsible or liable for any such statements.

Buyer acknowledges and agrees that it is solely responsible for compliance with all legal, regulatory and safety-related requirements concerning its products, and any use of TI components in its applications, notwithstanding any applications-related information or support that may be provided by TI. Buyer represents and agrees that it has all the necessary expertise to create and implement safeguards which anticipate dangerous consequences of failures, monitor failures and their consequences, lessen the likelihood of failures that might cause harm and take appropriate remedial actions. Buyer will fully indemnify TI and its representatives against any damages arising out of the use of any TI components in safety-critical applications.

In some cases, TI components may be promoted specifically to facilitate safety-related applications. With such components, TI's goal is to help enable customers to design and create their own end-product solutions that meet applicable functional safety standards and requirements. Nonetheless, such components are subject to these terms.

No TI components are authorized for use in FDA Class III (or similar life-critical medical equipment) unless authorized officers of the parties have executed a special agreement specifically governing such use.

Only those TI components which TI has specifically designated as military grade or "enhanced plastic" are designed and intended for use in military/aerospace applications or environments. Buyer acknowledges and agrees that any military or aerospace use of TI components which have **not** been so designated is solely at the Buyer's risk, and that Buyer is solely responsible for compliance with all legal and regulatory requirements in connection with such use.

TI has specifically designated certain components as meeting ISO/TS16949 requirements, mainly for automotive use. In any case of use of non-designated products, TI will not be responsible for any failure to meet ISO/TS16949.

Products

Audio	www.ti.com/audio
Amplifiers	amplifier.ti.com
Data Converters	dataconverter.ti.com
DLP® Products	www.dlp.com
DSP	dsp.ti.com
Clocks and Timers	www.ti.com/clocks
Interface	interface.ti.com
Logic	logic.ti.com
Power Mgmt	power.ti.com
Microcontrollers	microcontroller.ti.com
RFID	www.ti-rfid.com
OMAP Applications Processors	www.ti.com/omap
Wireless Connectivity	www.ti.com/wirelessconnectivity

Applications

Automotive and Transportation	www.ti.com/automotive
Communications and Telecom	www.ti.com/communications
Computers and Peripherals	www.ti.com/computers
Consumer Electronics	www.ti.com/consumer-apps
Energy and Lighting	www.ti.com/energy
Industrial	www.ti.com/industrial
Medical	www.ti.com/medical
Security	www.ti.com/security
Space, Avionics and Defense	www.ti.com/space-avionics-defense
Video and Imaging	www.ti.com/video

TI E2E Community

e2e.ti.com